

Description

Miniaturised single pole thermal circuit breaker with switching function optional (push-push actuation). Reliable snap-acting and trip-free mechanism. Approved to CBE standard EN/IEC 60934. S-type, TO. Blade terminals fitting into sockets for rail mounting.

Typical applications

Protection of loads in power distribution systems in control cabinets and process control.

Ordering information

Type No.

1180 single pole thermal circuit breaker, plug-in mounting

Versions

01 with switching function, without label

02 reset function only, without label

Current rating range

0.1...10 A

1180 - 01 - 1 A ordering example

Preferred types

NEW

Preferred types	Standard current ratings (A)										
	0.5	1	1.5	2	2.5	3	4	5	6	8	10
1180-01-	x	x	x	x	x	x	x	x	x	x	x

Standard current ratings and typical internal resistance values

Current rating (A)	Internal resistance (Ω)	Current rating (A)	Internal resistance (Ω)
0.1	81	2	0.25
0.2	22	2.5	0.18
0.25	14	3	0.11
0.3	8.7	3.5	0.08
0.4	5.5	4	0.07
0.5	3.4	5	≤ 0.05
0.6	2.5	6	≤ 0.05
0.7	1.7	7	≤ 0.05
0.8	1.5	8	≤ 0.05
1	0.9	10	≤ 0.05
1.5	0.4		

Approvals

Authority	Voltage ratings	Current ratings
VDE	AC 250 V; DC 65 V	0.1...10 A
UL	AC 250 V; DC 72 V	0.1...10 A
CSA	AC 250 V; DC 72 V	0.1...10 A



1180-...

Technical data

Voltage rating	AC 250 V; DC 65 V (UL, UL Canada: AC 250 V; DC 72 V)	
Current ratings	0.1...10 A	
Typical life	6,000 operations at 1 x I _N (low-inductance) 3,000 operations at 1 x I _N (inductive) 500 operations at 2 x I _N (inductive)	
Ambient temperature	-20...+60 °C (T 60)	-4...+140 °F
Insulation co-ordination (IEC 60664 and 60664 A)	rated impulse withstand voltage 2.5 kV reinforced insulation in operating area	pollution degree 2
Dielectric strength (IEC 60664 and 60664A)	test voltage AC 3,000 V operating area AC 1,500 V installation area	
Insulation resistance	> 100 MΩ (DC 500 V)	
Interrupting capacity I _{cn}	0.1...5 A 6 x I _N AC 250 V, DC 65 V 6...10 A 8 x I _N AC 250 V, DC 65 V 0.1...0.7 A 25 x I _N DC 30 V 0.8...6 A 10 x I _N DC 30 V 7...10 A 20 x I _N DC 30 V	
Interrupting capacity (UL 1077)	AC 250 V 2,000 A DC 72 V 2,000 A	
Degree of protection (IEC 60529/DIN 40050)	operating area IP40 terminal area IP00	
Vibration without terminal block	5 g (57-500 Hz) ± 0.38 mm (10-57 Hz) to IEC 60068-2-6, test Fc, 10 frequency cycles/axis and to EN 50155	
Shock without terminal block	25 g (11 ms) to IEC 60068-2-27, test Ea	
Corrosion	96 hours at 5 % salt mist, to IEC 60068-2-11, test Ka	
Humidity	240 hours at 95 % RH to IEC 60068-2-78, test Cab	
Mass	approx. 15 g	

Dimensions

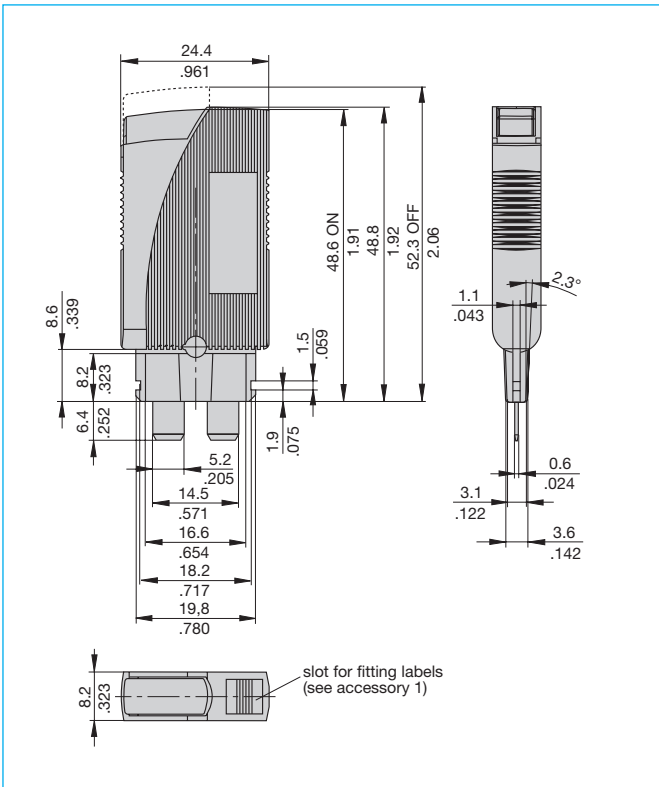

Typical time/current characteristics at +23 °C/73.4 °F

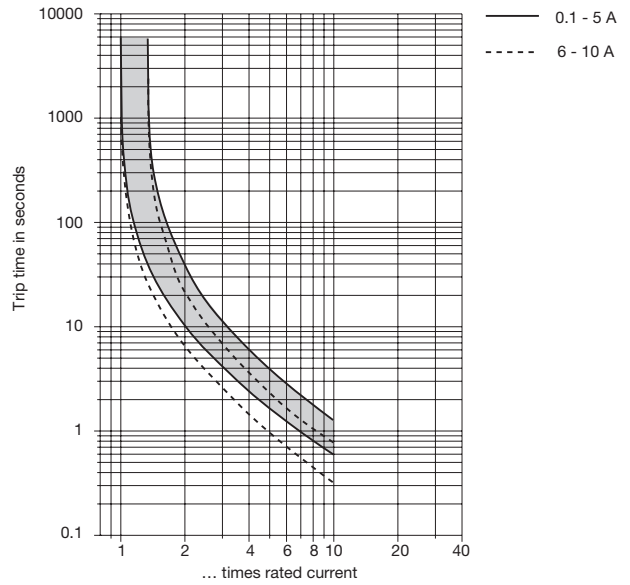

The time/current characteristic curve depends on the ambient temperature prevailing. In order to eliminate nuisance tripping, please multiply the circuit breaker current ratings by the derating factor shown below. See also section Technical information.

Ambient temperature °F	-22	-4	+14	+32	+73.4	+104	+122	+140
°C	-20	-10	0	+23	+40	+50	+60	+60
Derating factor	0.8	0.76	0.84	0.92	1	1.08	1.16	1.24

Internal connection diagram

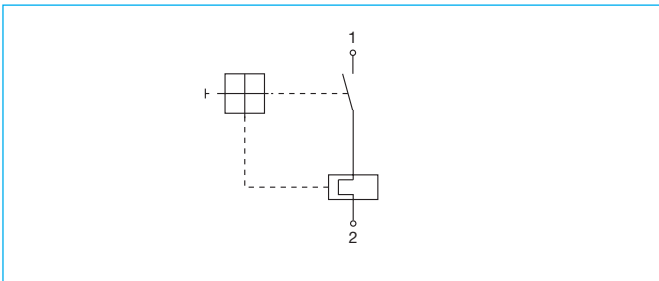

Shock directions

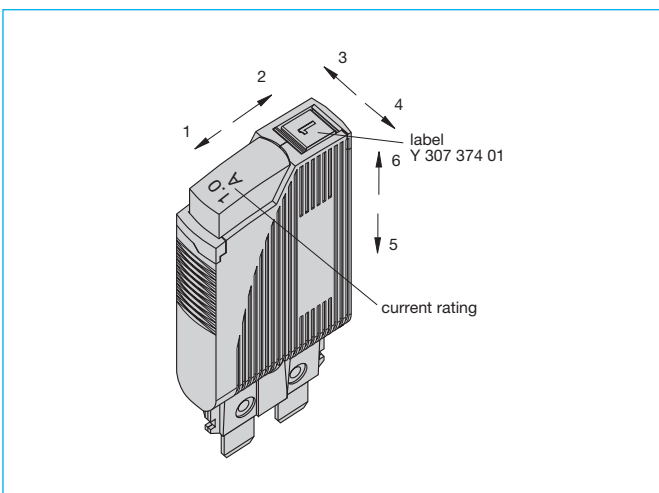

Note: When several devices are mounted together, each device should only carry 80 % of its rating or it must be overrated accordingly.

This is a metric design and millimeter dimensions take precedence ($\frac{\text{mm}}{\text{inch}}$)

Accessories - Terminal block with screw terminals

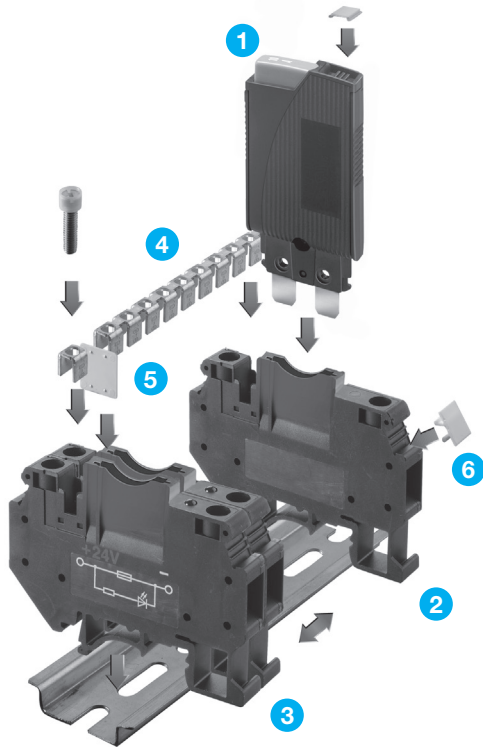

1 Label for circuit breaker 1180, surface for marking 4.5 x 5 mm (packaging quantity 120 pcs)
Y 307 374 01

2 Terminal block for DIN rail mounting, with screw terminals up to 6 mm² conductor, width 8.2 mm, dimensions 64 x 42.5 x 8.2 mm, headroom over the upper rail edge with circuit breaker fitted (OFF position) 84 mm.
Approvals: UL File E197598
X 222 233 01

3 Terminal block for DIN rail mounting see item 2, but with LED DC 24 V (lighted after tripping); current rating LED 2 mA
Approvals: UL File E197598
X 222 233 02

4 Bus connection for potential bridging of several terminal blocks see item 2 and 3 (10-pole, separable, mounting hardware included), max. current rating 34 A
X 222 232 01

5 Insulation barriers for insertion between two circuits (packaging quantity 10 pcs)
Y 307 373 01

6 Label for terminal block, see item 2 and 3, surface for marking 8 x 10 mm (packaging quantity 10 pcs)
Y 307 375 01

Dimensions X 222 233 02

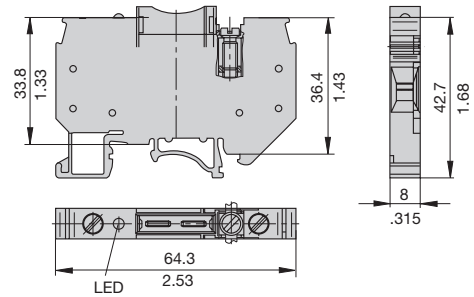

Vibration	with terminal block X 222 233 01 and X 222 233 02 5 g (57-500 Hz), ± 0.38 mm (10-57 Hz) to IEC 60068-2-6, test Fc, 10 frequency cycles/axis and EN 50155
Shock	with terminal block X 222 233 01 and X 222 233 02 25 g (11 ms) to IEC 60068-2-27, test Ea

This is a metric design and millimeter dimensions take precedence ($\frac{\text{mm}}{\text{inch}}$)

Accessories - Terminal block with spring-loaded terminals

2

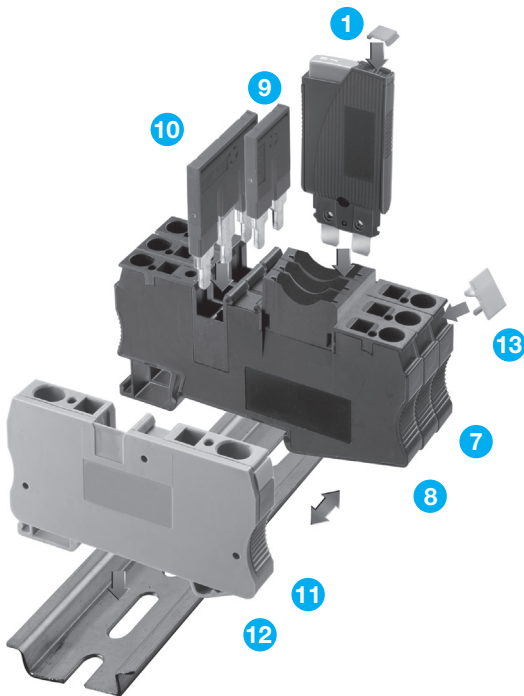

- 1 Label** for circuit breaker 1180, surface for marking 4.5 x 5 mm (packaging quantity 120 pcs)
Y 307 374 01

- 7 Terminal block** for DIN rail mounting, with spring-loaded terminals up to 4 mm² conductor, width 8.2 mm, dimensions 68.5 x 36.5 x 8.2 mm, headroom over the upper rail edge with circuit breaker fitted (OFF position) 82 mm.
Approvals: UL File E197598
X 222 316 01

- 8 Terminal block** for DIN rail mounting see item 7, but with LED DC 24 V (lighted after tripping); current rating LED 2 mA
Approvals: UL File E197598
X 222 315 02

- 9 Jumper 2pole**, max. current rating 32 A for terminal blocks items 7 and 8 and feed supply terminal item 11.
X 222 318 01

- 10 Jumper 3pole**, max. current rating 32 A for terminal blocks items 7 and 8 and feed supply terminal item 11.
X 222 318 02

- 11 Feed supply terminal** with spring-loaded terminals up to 6 mm² conductor, width 8.2 mm, suitable for use with jumpers items 9 and 10 (power distribution).
X 222 317 01

- 12 Cover** for feed supply terminal item 11 for closing the open side at the end of an assembly.
Y 307 507 01

- 13 Label** for terminal block items 7 and 8, and feed supply terminal item 11, surface for marking 7.5 x 5 mm (packaging quantity 50 pcs)
Y 307 508 01

Dimensions X 222 316 01

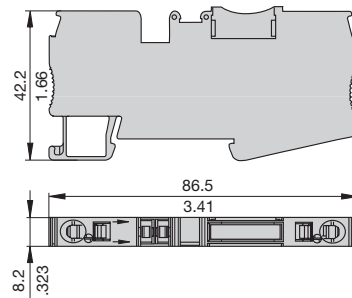

Vibration	with terminal blocks X 222 316 01 and X 222 315 02 vibration axis 3-4: 3 g (57-500 Hz), ± 0.38 mm (10-57 Hz) other axes: 5 g (57-500 Hz), ± 0.38 mm (10-57 Hz) to IEC 60068-2-6, test Fc, 10 frequency cycles/axis and EN 50155
Shock	with terminal blocks X 222 316 01 and X 222 315 02 25 g (11 ms) to IEC 60068-2-27, test Ea

This is a metric design and millimeter dimensions take precedence $\left(\frac{\text{mm}}{\text{inch}}\right)$

All dimensions without tolerances are for reference only. In the interest of improved design, performance and cost effectiveness the right to make changes in these specifications without notice is reserved. Product markings may not be exactly as the ordering codes. Errors and omissions excepted.