

# User Manual

## *ControlPlex*<sup>®</sup> Controller CPC12EN



# 1 Table of contents

<b>1</b>	<b>Table of contents</b>	<b>2</b>
<b>2</b>	<b>General information</b>	<b>4</b>
2.1	Safety instructions	4
2.2	Qualified personnel	4
2.3	Use	4
2.4	Delivery state	4
<b>3</b>	<b>General description</b>	<b>5</b>
3.1	Design of the entire system	6
3.2	Dimensions CPC12xx-Tx	7
3.3	Status indication and terminals	7
3.3.1	Terminals for voltage supply	8
3.3.2	EtherNet/IP interfaces with integral switch, connection sleeve XF1, XF2	8
3.3.3	ETHERNET interface, connection sleeve X1	8
3.3.4	LED status indication	8
<b>4</b>	<b>Mounting and installation</b>	<b>9</b>
4.1	Mounting of the system	9
<b>5</b>	<b>Operating modes of the CPC12 bus controller</b>	<b>10</b>
5.1	Operating mode: Start-up mode	10
5.2	Operating mode: System error mode	10
5.3	Operating mode: Configuration error mode	10
5.4	Operating mode: Stand-alone mode	10
5.5	Operating mode: Slave mode	10
5.6	Operating mode: Firmware Update Mode	10
<b>6</b>	<b>Basic functions of the entire system</b>	<b>11</b>
6.1	Internal cycle times	11
6.2	Hot swap of circuit protectors	11
6.3	About the additional Ethernet interface	11
6.3.1	Web Server	11
6.3.2	Default IP address -X1	11
6.3.3	User name and password	11
6.3.4	OPC UA	11
6.3.5	MQTT	11

<b>7</b>	<b>Communication via EtherNet/IP™</b>	<b>12</b>
7.1	<b>ControlPlex®</b> device model	12
7.2	EDS file	13
7.3	Identity Object (Class ID: 0x01)	13
7.4	TCP/IP Interface Object (Class ID: 0xF5)	13
<b>8</b>	<b>Cyclical I/O data</b>	<b>14</b>
8.1	I/O data input: CPC12 controller	14
8.2	I/O data input: total current	14
8.3	I/O data input: circuit protectors	15
8.4	I/O data output: circuit protectors	16
<b>9</b>	<b>Non-cyclical data</b>	<b>17</b>
9.1	CPC12 controller	18
9.1.1	Device information CPC12 controller	18
9.1.2	Configuration data CPC12 controller	19
9.1.3	Action commands CPC12 controller	20
9.1.4	Dynamic information CPC12 controller	21
9.2	Circuit protectors/channels	21
9.2.1	Device parameters for one channel	21
9.2.2	Device information for one channel	21
9.2.3	Configuration data for one channel	23
9.2.4	Event message for one channel	24
9.2.5	Action commands for one channel	24
9.2.6	Diagnostic data for one channel	25
<b>10</b>	<b>Appendix</b>	<b>27</b>
10.1	List of pictures	27

## 2 General information

### 2.1 Safety instructions

This manual points out possible danger for your personal safety and gives instruction how to avoid property damage. The following safety symbols are used to draw the reader's attention to the safety instructions included in this manual.



#### **Danger!**

Danger to life and limb unless the following safety precautions are taken.



#### **Warning**

Danger to machinery, materials or the environment unless the following safety precautions are taken.



#### **Note**

Information is provided to allow a better understanding.



#### **Caution**

Electrostatically sensitive devices (ESD). Devices must exclusively be opened by the manufacturer.



#### **Disposal guidelines**

Packaging can be recycled and should generally be brought to re-use.

### 2.2 Qualified personnel

This user manual must exclusively be used by qualified personnel, who are able – based on their training and experience – to realise arising problems when handling the product and to avoid related hazards. These persons have to ensure that the use of the product described here meets the safety requirements as well as the requirements of the presently valid directives, standards and laws.

### 2.3 Use

The product is part of a continuous enhancement process. Therefore, there might be deviations between the product in hand and this documentation. These deviations will be remedied by a regular review and resulting corrections in future editions. The right to make changes without notice is reserved. Error and omissions excepted.

### 2.4 Delivery state

The product is supplied with a defined hardware and software configuration. Any changes in excess of the documented options are not permitted and lead to liability exclusion.

### 3 General description

The customers' demands for a constant quality of the produced goods, while at the same time increasing the quantities, pose great challenges to the mechanical and plant engineering industry. At the same time, globalisation is creating worldwide value flows and production chains. Machines and plants that had still been regionally organised just a few years ago are now networked worldwide. These developments extend the requirements of machine and plant control as well as of the installed components. An ever growing number of measuring data need to be recorded, analysed, evaluated and saved. This increases the transparency of the manufacturing process and thus system availability.

The DC 24 V power distribution is also affected by this development. The control voltage supplies all essential components of the machine or system. These include, besides programmable control units, for example actuators and sensors. Therefore, the control voltage has a special importance in the entire production process. Its availability and stability are crucial for system availability and quality of the produced goods. The REX system is equal to the task. It consists of electronic circuit protectors which are connected with each other via an integrated connector arm without requiring additional components. Power supply is via the EM12 supply module which can supply the circuit protectors with max. 40 A. The new CPC12 bus controller additionally allows access to all

system-relevant data of the superordinate control systems. This can be done via the EtherNet/IP™ interface as well as via an additional Ethernet interface.

The CPC12 connects the circuit protectors with the superordinate control unit. Its internal **ELBus**® interface realises the connection with the REX intelligent circuit protectors<sup>1</sup>. The CPC12 allows entire access on all required parameters of the electronic circuit protectors, their control unit and the visualisation of the device data.

This is made available at the fieldbus interface for the superordinate control unit and also at the third RJ45 interface for further connection. Thus the system offers a fully parameterisable protection of the DC 24 V circuits and ensures selective overcurrent protection of sensors and actuators, decentralised peripheral sub-assemblies etc. and there supply lines.

<sup>1</sup> To simplify presentation and explanation, the naming of intelligent circuit breakers is limited to the system designation REX. This designation includes the REX12D and REX22D circuit breakers.

### 3.1 Design of the entire system

The CPC12 bus controller is the centre piece of the **ControlPlex**® system. It allows consistent communication between the electronic circuit protectors and the superordinate control level, connected HMIs and even into the Cloud.

The EtherNet/IP™ interface to the superordinate control unit is implemented as two RJ45 connectors. It allows connection of the required control unit with the **ControlPlex**® system. This enables display, analysis as well as diagnosis of the individual measuring values. In addition, it allows control of the individual electronic circuit protectors. An additional Ethernet interface enables direct access of the integral web server of the bus controller. Service staff can thus directly access the system on site. Moreover, access via the connected infrastructure of the company is enabled and thus global access. OPC UA and MQTT allow transmission of all measuring values and status information independently of

the control system, e.g. to a superordinate cloud application. Revised measuring values of all electronic circuit protectors are also forwarded to the automation system. This enables the user to have unrestricted access to the safety-relevant functions even in the event of an interruption. Any occurring failures will be detected quickly and can be remedied without delay. The **ControlPlex**® system effectively reduces system downtimes and significantly increases the productivity.

The CPC12 bus controller allows connection of up to 16 double channel electronic circuit protectors:

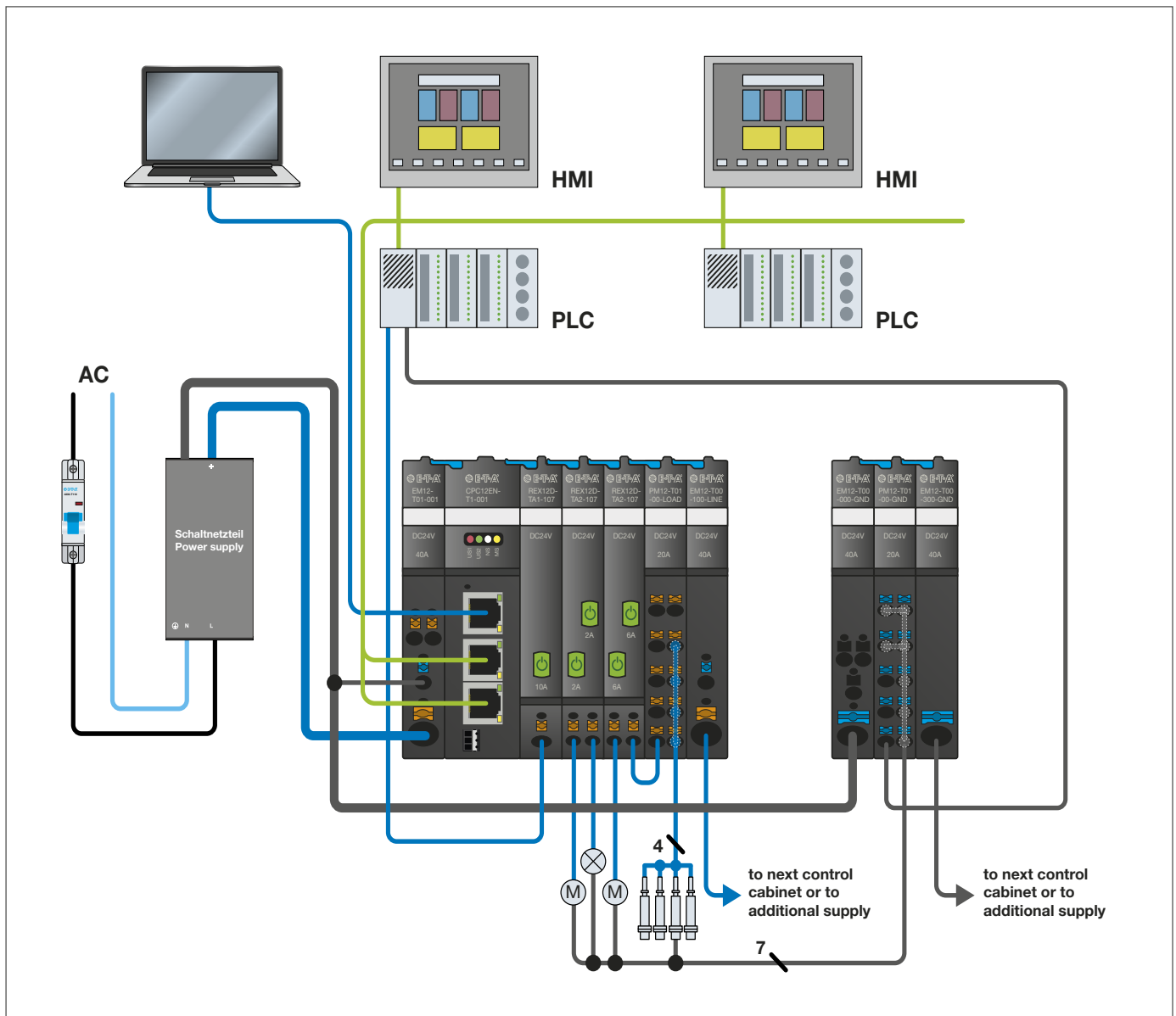

fig. 1: System overview

### 3.2 Dimensions CPC12xx-Tx

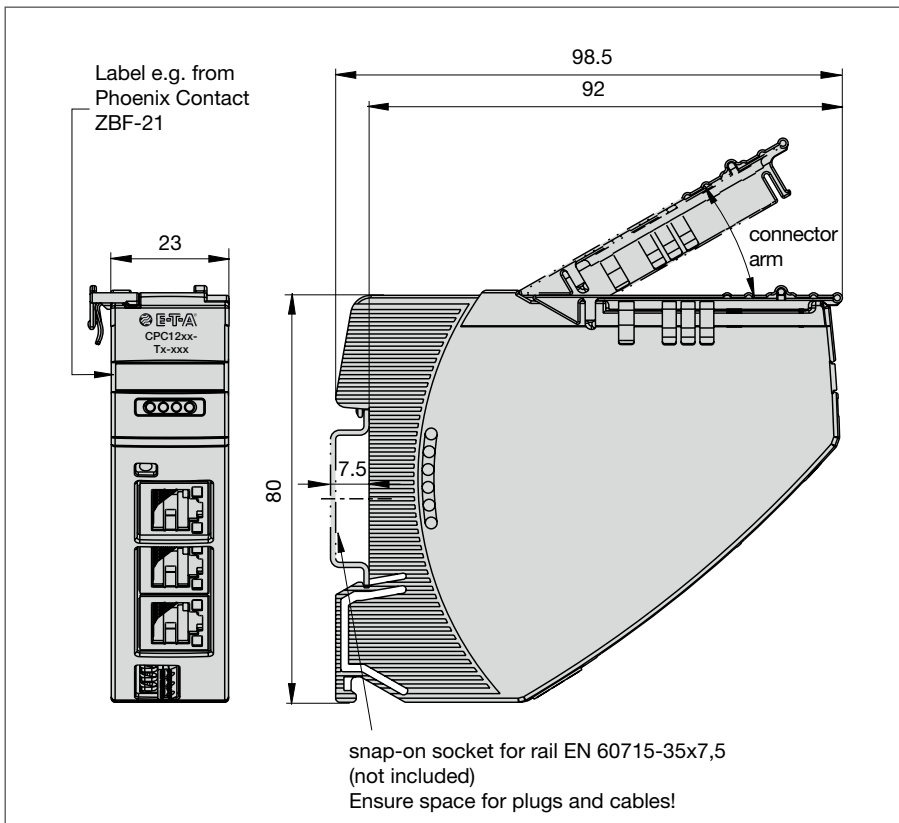

fig. 2: Dimensions CPC12

### 3.3 Status indication and terminals

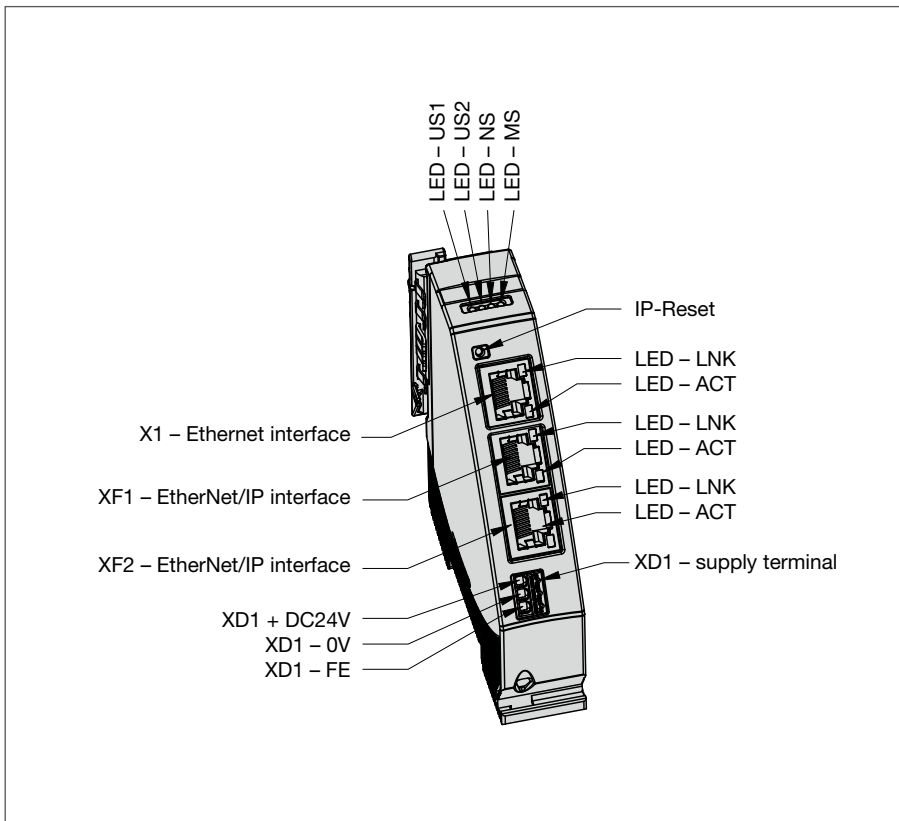

fig. 3: Status indication and terminals

### 3.3.1 Terminals for voltage supply

Supply XD1

Voltage ratings: DC 24 V( $\pm 5\%$  18 ... 30 V)

Rated current: typically 75 mA

Terminal design: 3 x push-in terminals (+0V/ FE)

Max. cable cross section rigid	0.2 – 1.5 mm <sup>2</sup>
flexible with wire end ferrule (without plastic sleeve)	0.2 – 1.5 mm <sup>2</sup>
flexible with wire end ferrule (with plastic sleeve)	0.2 – 0.75 mm <sup>2</sup>
cable cross section	AWG24 – AWG16 str.
stripping length	8 mm



Using a supply voltage outside the indicated operating range can cause malfunctions or destruction of the device.



The power supply of the CPC12 bus controller is also ensured by the EM12 supply module through the integrated connector arm. The use of the power supply terminal XD1 is optional.

### 3.3.2 EtherNet/IP interfaces with integral switch, connection sleeve XF1, XF2

XF1 Connection to bus system EtherNet/IP  
Type: RJ45

When wiring and connecting to the bus system EtherNet/IP, the installation and wiring regulations of the EtherNet/IP™ Specification have to be observed.

XF2 Connection to bus system EtherNet/IP  
Type: RJ45

When wiring and connecting to the bus system EtherNet/IP, the installation and wiring regulations of the EtherNet/IP™ Specification have to be observed.

### 3.3.3 ETHERNET interface, connection sleeve X1

X1 Connection with the bus controller CPC12 and the integral web server  
Type: RJ45

### 3.3.4 LED status indication

Visual status indication by means of multicolored LED

Operating mode	Indication of operating mode	
	LED US1	LED US2
Supply voltage OK	green	n.a.
Firmware update	off	off
Actuator voltage OK	green	green
No actuator voltage	green	red
No connected device or bus error	green	orange blinking

fig. 4: Display status LEDs  
n.a. = not applicable



### LED NS (Network Status)

Operating mode	Indication of operating mode
No IP-Address	off
Valid IP-Address, no CIP-Connection	green blinking
Active CIP-Connection	green
CIP-Connection timeout	red blinking
Double IP detected	red

fig. 5: Display fieldbus status LEDs

### LED MS (Module Status)

Operating mode	Indication of operating mode
Switched off	off
Operation mode	green
Device not configured	green blinking
Severe but recoverable error	red blinking
Severe not recoverable error	red

Visual signaling of RJ45 interfaces

### LED LNK

Operating mode	Indication of operating mode
Link available	green
No link available	off

fig. 6: Display LEDs RJ45 connectors

### LED ACT

Operating mode	Indication of operating mode
Act available	orange blinking
No Act available	off

## 4 Mounting and installation

### 4.1 Mounting of the system

The preferred mounting position of the **ControlPlex®** system is horizontal.

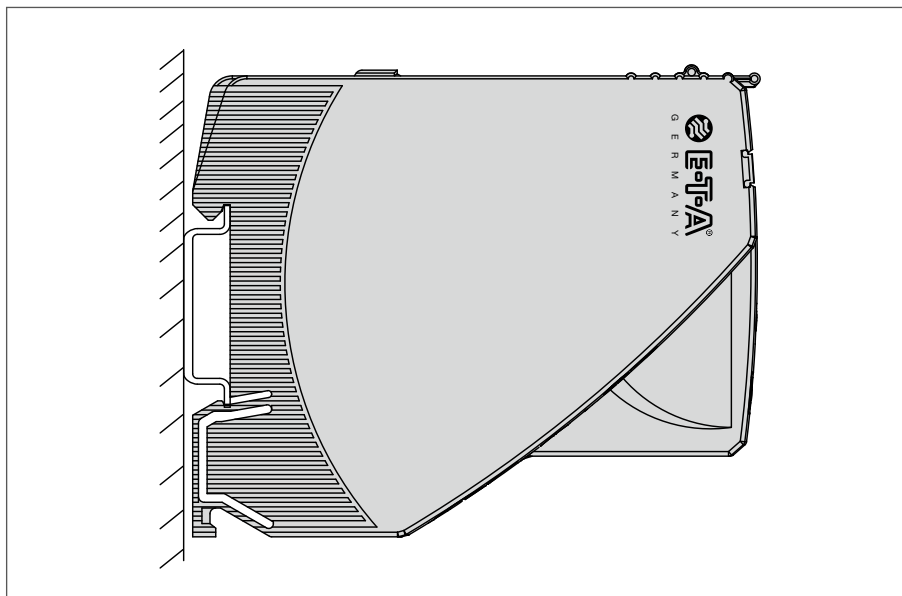

fig. 6: Installation drawing

# 5 Operating modes of the CPC12 bus controller

## 5.1 Operating mode: Start-up mode

The CPC12 bus controller is initialised by applying the supply voltage. The device will carry out internal program memory tests and self test routines. During this time a communication via the interfaces is not possible.

## 5.2 Operating mode: System error mode

If a failure is detected during the self test routines, the bus controller will change into operating mode System Error. This operating mode can only be discontinued by way of re-starting the device and it prevents the data exchange via the interfaces. If the bus controller is in this operating mode, it is unable to control the electronic circuit protectors and these will stay in the stand-alone mode (overcurrent protection).

## 5.3 Operating mode: Configuration error mode

If there are no valid or invalid configuration data available in the bus controller, it will change into this operating mode. This operating mode only allows non-cyclical data exchange. Cyclical data exchange is prevented. Leave this operating mode upon receipt of the correct slot parameters and configuration data.

## 5.4 Operating mode: Stand-alone mode

In this operating mode there is no connection between the bus controller and the superordinate control unit. In this case the CPC12 bus controller will automatically adopt the control and parameterisation of the electronic circuit protectors, because all required data sets are saved within the CPC12. By means of the web server, the electronic circuit protectors, their status and parameters can be accessed via the Ethernet interface. It is thus possible to change e.g. parameter data of the various electronic circuit protectors. After a fieldbus connection is established, this operating mode will be left and the control unit will take over control again as master. If during this time a parameter was changed while there was no communication, this will be signaled to the superordinate control unit. In this case the user can correspondingly define the control behavior and it can be programmed in the programmable control unit. This allows the user to select a reaction meeting his requirements.

## 5.5 Operating mode: Slave mode

In this operating mode, the CPC12 is connected to a EtherNet/IP system. Communication to the CPC12 bus controller works faultlessly and the controller can be addressed and controlled by the superordinate control unit. Should the communication fail, this has no influence on the protective function of the circuit protectors. The behavior of the bus controller with simultaneous use of a field bus interface and of the web server interface can be determined by means of the configuration of the device in the superordinate control unit.

It can be pre-selected there that Ethernet interface or the Web Server are granted either only reader access or reader and editor access. In the event of editor access, changes of the parameterisation of the electronic circuit protectors can be carried out in parallel to the field bus system. These parameter changes will then be advised to the superordinate control system and can be adopted by it or also overwritten. The user can select the behavior accordingly.

## 5.6 Operating mode: Firmware Update Mode

The devices are supplied with a software programmed according to their functionality. If the functions of the devices are extended, they will be added by firmware update. It is therefore necessary to carry out a firmware update if the new functionality shall be used.

# 6 Basic functions of the entire system

## 6.1 Internal cycle times

The cycle time of the system depends on the number of electronic circuit protectors connected and on the internal baud rate. The internal baud rate can be 9600 or 19200 baud. The baud rate is only changed to 19200 when all connected circuit protectors support this function. The baud rate is signaled in the cyclical data in the »Status Controller«. The current cycle time can be retrieved with the non-cyclical access to the »dynamic information of the CPC12«.

The cycle time in the case of 16 circuit protectors and an internal baud rate of 9600 baud is approx. 480 ms for the cyclical data, i.e. 30 ms per unit. A window of 130 ms is kept free for non-cyclical data. In total, this is a max. cycle time of 610 ms.

An internal baud rate of 19200 baud reduces the cycle time for the cyclical data to some 240 ms, i.e. 15 ms per unit. A window of 100 ms is kept free for non-cyclical data. In total, this is a max. cycle time of 340 ms.

## 6.2 Hot swap of circuit protectors

If a new circuit protector is added to an existing application, it will automatically be parameterised with the available parameters for address slot. Transmission of the parameters will be without interruption of the cyclical data exchange between the CPC and the electronic circuit protector.

## 6.3 About the additional Ethernet interface

The additional Ethernet interface (X1) extends the functional scope of the bus controller. The following functionalities are provided via this interface.

### 6.3.1 Web Server

The web server offers the entire scope of measuring data, status information, parameterisation options and control function of the CPC12 bus controller. The parameterisation of the interface is described separately.

### 6.3.2 Default IP address -X1

The default IP address of the CPC12 is:

IP-Address	192.168.1.1
Netmask	255.255.255.0
Gateway	192.168.1.254

The web server can be reached via this IP address. By pressing the IP reset button for 3 seconds, the IP address is reset to the default value.

### 6.3.3 User name and password

In order to be able to carry out configurations, the user has to have the required access authorisation. It is defined in user administration.

The default settings are:

User	admin
Password:	admin



We urgently recommend to individually adjust these settings upon startup of the device.

### 6.3.4 OPC UA

This functionality will only be included and described in a later version.

### 6.3.5 MQTT

This functionality will only be included and described in a later version.

# 7 Communication via EtherNet/IP™

EtherNet/IP™ is a network adaption of the Common Industrial Protocol (CIP™) developed by the ODVA organization. CIP uses abstract object modeling to describe the available communication services and data provided by a product. Objects and their components are addressed by an addressing scheme consisting of Node Address (IP-Address), Class Identifier (Class ID), Instance Identifier (Instance ID), Attribute Identifier (Attribute ID) and a Service Code. Assembly objects are used for I/O messages by combining several I/O data into one block.

The IP-Address is typically assigned by a DHCP-server within the network.

Supported EtherNet/IP Features: Address Conflict Detection (ACD), Quality of Service (QoS), Device Level Ring (DLR) - Media Redundancy

## 7.1 ControlPlex® device model

The power distribution system with CPC12 controller consists of a passive supply module EM12-T00-000-DC24V-40A and up to 16 intelligent circuit protectors of the REX series.

The power distribution system **ControlPlex®** uses the following EtherNet/IP model:

EtherNet/IP	CPC12EN
<b>Class 0x01, 0x06, 0x47, 0xF5, 0xF6</b>	The EtherNet/IP interface requires several mandatory objects. These are the identity object (0x01), the connection manager object (0x06), the device level ring object (DLR, 0x47), the TCP/IP interface object (0xF5) and the ethernet link object (0xF6).
<b>Class 100</b>	Class 100 represents the CPC12EN controller. All system wide information and settings can be accessed through this class. Details are described in Chapter 9. The I/O data of the CPC12EN are described in chapter 8.1.
<b>Class 101</b>	<p>Class 101 represents the circuit protectors connected to the CPC12EN. All circuit breaker specific information and settings can be accessed through this class. Details are described in Chapter 9.</p> <p>The I/O data of each circuit protector contain the control byte, the status byte and measuring values. The process data image of the PLC holds 10 input bytes and 2 output bytes for each circuit protector. Details are described in chapter 8.2. The quantity of cyclically exchanged process data is adjustable.</p> <p>If fewer circuit protectors are connected than configured, the status of the missing circuit protectors is marked as »not available«.</p> <p>If more circuit protectors than configured are connected, these cannot be accessed by the PLC.</p> <p> The CPC12 allows configuration of 1 to max. 16 circuit protectors.</p>

fig. 8: Communication properties

## 7.2 EDS file

The EDS file is provided in the download area of the E-T-A website and can be downloaded there.

## 7.3 Identity Object (Class ID: 0x01)

The identity object supports only instance 1.

Service codes Get\_Attributes\_All (1) and Get\_Attribute\_Single (14) are supported.

Further details are provided by the EtherNet/IP™ Specification.

Name	Attribute ID	Data Type	Description
Vendor ID	1	UINT	Vendor identification
Device Type	2	UINT	General type of product
Product Code	3	UINT	Product code of vendor
Revision	4	USINT, USINT	Revision of the item
Status	5	WORD	Summary status of device
Serial Number	6	UDINT	Serial number of device
Product Name	7	SHORT_STRING	Profile ID
State	8	USINT	2 = Standby 3 = Operational 4 = Major Recoverable Fault 5 = Major Unrecoverable Fault
Configuration Consistency Value	9	UINT	
Heartbeat Interval	10	USINT	

fig. 9: Identity Object Attributes

## 7.4 TCP/IP Interface Object (Class ID: 0xF5)

The TCP/IP interface object supports only instance 1.

Service codes Get\_Attributes\_All (1) and Get\_Attribute\_Single (14) are supported.

Further details are provided by the EtherNet/IP™ Specification.

Name	Attribute ID	Data Type	Description
Status	1	DWORD	Interface status
Configuration Capability	2	DWORD	Interface capability flags
Configuration Control	3	DWORD	0 = Statically-assigned IP configuration 1 = IP-configuration via BOOTP 2 = IP-configuration via DHCP
Physical Link Object	4	STRUCT	Path to physical link object
Interface Configuration: IP Address, Network Mask, Gateway Address, Name Server, Name Server 2, Domain Name	5	STRUCT of: UDINT, UDINT, UDINT, UDINT, UDINT, STRING	IP-configuration
Host Name	6	STRING	Host name

fig. 10: TCP/IP Interface Object Attributes

## 8 Cyclical I/O data

EtherNet/IP™ provides the exchange of cyclical process data from an originator (e.g. PLC) to the target (CPC12EN) O→T and vice versa T→O. The number of exchanged I/O data bytes can be varied.

The Forward\_Open request to the connection manager initiates the I/O communication and determines the requested packet interval (RPI), the priority, the data size and the connection path. Valid RPI range for the CPC12EN is between 1 ms and 1000 ms. One exclusive owner, one listen only and one input only connection is supported simultaneously.

The O→T connection includes a Run/Idle Header which account for the first 4 bytes.

The O→T assembly (100) data size is adjustable between 0 and 32 bytes.

The T→O assembly (101) data size is adjustable between 0 and 164 bytes.

The connection path must be set to 0x20 04 24 00 2C 64 2C 65 because no configuration assembly is used.

The EDS file made available for the projecting tool allows the related configuration.

### 8.1 I/O data input: CPC12 controller

Originator→Target bytes 0...1

The 2 input bytes contain the following global error and diagnostic messages.

	Byte	Type	Range	Description
status controller	0 HighByte 1 LowByte	UInt16	0xFFFF	bit 0 = no configuration data available bit 1 = invalid configuration data bit 2 = connected device type differs from configuration bit 3 = reserve bit 4 = command buffer overflow bit 5 = no communication to <b>ELBus</b> ® 1 bit 6 = reserve bit 7 = reserve bit 8 = reserve bit 9 = CPC temporary error bit 10 = CPC hardware error bit 11 = <b>ELBus</b> ® 1 communication speed: 0=9600 Baud, 1=19200 Baud bit 12 = reserve bit 13 = reserve bit 14 = reserve bit 15 = writing access via web server deactivated = 1, allowed = 0

fig. 11: Cyclical diagnostic data CPC12

### 8.2 I/O data input: total current

Originator→Target bytes 2...3

The total current supplies a standardized 16-bit value with the calculated total current of all circuit protectors (2 byte input data).

The measuring value is indicated as follows:

	Byte	Type	Range	Description
Total current	0 HighByte 1 LowByte	UInt16	0 ... 65535	A standardised 16-bit-value with a resolution of 10 mA is made available. Example for calculation of the measuring value: value (1320)/ 100 $\hat{=}$ 13.20 Amps

fig. 12: Total current

### 8.3 I/O data input: circuit protectors

Originator→Target bytes 4...163

Each circuit protector has up to two channels. The input and output data are always transmitted for both possible channels.

10 bytes input data are exchanged for each circuit breaker containing the status of the channel, the load current and the load voltage. If the circuit protector used has only one channel, the status of the second channel is marked as not available (0xFF) and the load current and the load voltage are set to 0.

Design of the input bytes per circuit protector is as follows:

	Byte	Type	Range	Description
Status channel	0	byte	0 ... 255	0xFF (255) $\hat{=}$ no device available or wrong configuration bit 0 = load output ON bit 1 = short circuit bit 2 = overload bit 3 = low voltage bit 4 = reserve bit 5 = reserve bit 6 = limit value current bit 7 = event / or button pressed »True« means the status is active.
Load current channel 1	1 HighByte 2 LowByte	UInt16	0 ... 65535	A standardised 16-bit-value with a resolution of 10 mA is made available. Example for calculation of the measuring value: value (150)/100 $\hat{=}$ 1.50 Amps
Load voltage channel 1	3 HighByte 4 LowByte	UInt16	0 ... 65535	A standardised 16-bit-value with a resolution of 10 mV is made available. Example for calculation of the measuring value: value (2512)/100 $\hat{=}$ 25.12 Volt
Status channel 2	5	byte	0 ... 255	0xFF (255) $\hat{=}$ no device available, wrong configuration or 1-channel device used bit 0 = load output ON bit 1 = short circuit bit 2 = overload bit 3 = low voltage bit 4 = reserve bit 5 = reserve bit 6 = limit value current bit 7 = event / or button pressed »True« means the status is active.
Load current channel 2	6 HighByte 7 LowByte	UInt16	0 ... 65535	A standardised 16-bit-value with a resolution of 10 mA is made available. Example for calculation of the measuring value: value (150)/100 $\hat{=}$ 1.50 Amps
Load voltage channel 2	8 HighByte 9 LowByte	UInt16	0 ... 65535	A standardised 16-bit-value with a resolution of 10 mV is made available. Example for calculation of the measuring value: value (2512)/100 $\hat{=}$ 25.12 Volt

fig. 13: Input data circuit protector

## 8.4 I/O data output: circuit protectors

Target→Originator bytes 0...31

2 bytes output data are exchanged controlling the circuit protector.

Design of the output bytes per circuit protector is as follows:

	Byte	Type	Range	Description
Control channel 1	0	byte	0 ... 255	bit 0 = load output ON/OFF bit 1 = reset load output (only responds to rising edge 0 -> 1) bit 2 = reserve bit 3 = reserve bit 4 = reserve bit 5 = reserve bit 6 = reserve bit 7 = reserve »True« means the status is active.
Control channel 2	1	byte	0 ... 255	bit 0 = load output ON/OFF bit 1 = reset load output (only responds to rising edge 0 -> 1) bit 2 = reserve bit 3 = reserve bit 4 = reserve bit 5 = reserve bit 6 = reserve bit 7 = reserve »True« means the status is active.

fig. 14: Output data circuit protector

### Sample configuration:

8 REX circuit breakers with 16 channels are connected to the CPC12EN. The O→T data size can be configured to 84 input bytes and 16 bytes T→O data are provided.

Addressing of the output data is corresponding to the REX sequence.

circuit protector 1: channel 1.1 control input byte address[0]  
 circuit protector 1: channel 1.2 control input byte address[1]  
 circuit protector 2: channel 2.1 control input byte address[2]  
 circuit protector 2: channel 2.2 control input byte address[3]  
 circuit protector 3: channel 3.1 control input byte address[4]  
 .....

Addressing of the input data data is corresponding to the REX sequence.

Status controller: address [0..1],  
 total current: address [2..3]  
 circuit protector 1: channel 1.1 status: address [4], load current: address [5..6], load voltage: address [7..8]  
 circuit protector 1: channel 1.2 status: address [9], load current: address [10..11], load voltage: address [12..13]  
 circuit protector 2: channel 2.1 status: address [14], load current: address [15..16], load voltage: address [17..18]  
 circuit protector 2: channel 2.2 status: address [19], load current: address [20..21], load voltage: address [22..23]  
 .....



## 9 Non-cyclical data

Explicit EtherNet/IP messages allow exchange of further data with the CPC12 controller and the circuit protectors. Access also allows direct addressing of a circuit protector. EtherNet/IP Class, Instance and Attribute are required. For reading and editing CPC12 data, Class 100 is used. Class 101 is used for reading and editing the data of circuit protectors. The access to the circuit protectors is divided into channels. Two channels are provided per circuit protector.

The non-cyclical access to the data of CPC12 is divided as follows:

Class 100 and Class 101 support only service codes Get\_Attribute\_Single (14) and Set\_Attribute\_Single (16).

Class ID	Instance ID	Attribute ID	Number of data bytes	Reading (R) writing (W)	Description
100	1	1	19	R	Device information of CPC12 controller (see chapter 9.1.1).
100	1	3	5	R/W	Configuration data of CPC12 controller (see chapter 9.1.2).
100	1	4	1	W	Action commands for all channels and the CPC12 controller (see chapter 9.1.3).
100	1	2	4	R	Dynamic information of CPC12 controller (see chapter 9.1.4).

fig. 15: CPC12 Object Attributes

The non-cyclical access to the data of circuit protectors and/or channels is divided as follows:

Class ID	Instance ID	Attribute ID	Number of data bytes	Reading (R) writing (W)	Description
101	01 ... 32	3	2	R/W	Device parameters of a channel (see chapter 9.2.1).
101	01 ... 32	1	19	R	Device information of a channel (see chapter 9.2.2).
101	01 ... 32	6	2	R/W	Configuration data of a channel (see chapter 9.2.3).
101	01 ... 32	5	1	R	Event message of a channel (see chapter 9.2.4).
101	01 ... 32	4	1	W	Action commands for a channel (see chapter 9.2.5).
101	01 ... 32	2	22	R	Diagnosis data of a channel (see chapter 9.2.6).

fig. 16: Channel Object Attributes

## 9.1 CPC12 controller

The non-cyclical parameters of the controller are described in the following chapters.

### 9.1.1 Device information CPC12 controller

The device information of the controller consists of 19 bytes.

Class ID = 100, Instance ID = 1 and Attribute ID = 1

Service Code: Get\_Attribute\_Single (14)

All device information with possible conditions are described in the following table.

	Byte	Type	Range	Description
Device Type	0 HighByte 1 LowByte	UInt16	0 ... 65535	16469 = CPC12EN-T1 This list may be extended by future controllers.
Hardware version	2 HighByte 3 LowByte	UInt16	0 ... 65535	Holds the hardware version of the installed product
Internal assembly order numbers	4 HwHb 5 HwLB 6 LwHB 7 LwLB	UInt32	0 ... 4294967295	Holds the assembly order number of the installed product
Internal order split number	8 HighByte 9 LowByte	UInt16	0 ... 65535	Holds the internal order split number of the installed product
Production facilities number	10 HighByte 11 LowByte	UInt16	0 ... 65535	Holds the production facilities number of the installed product
Serial number	12 HwHb 13 HwLB 14 LwHB 15 LwLB	UInt32	0 ... 4294967295	Holds the serial number of the installed product
Software version (major.x.x)	16	byte	0 ... 255	Holds the major software version of the installed product
Software version (x.minor.x)	17	byte	0 ... 255	Holds the minor software version of the installed product
Software version (x.x.build)	18	byte	0 ... 255	Holds the build software version of the installed product

fig. 17: Device information CPC12

## 9.1.2 Configuration data CPC12 controller

The device configuration data for the controller consists of 5 bytes.

Class ID = 100, Instance ID = 1 and Attribute ID = 3

Service Code: Get\_Attribute\_Single (14), Set\_Attribute\_Single (16)

All configuration data with possible conditions are described in the following table.

	Byte	Type	Range	Description
Configuration data of the CPC	0	byte	0 ... 255	<p>bit 0 = writing via web server permitted. Allows changing of parameters via the server even when the bus connection is active.</p> <p>bit 1 True: In the event of a fieldbus interruption, the status of the load outputs is maintained. False: In the event of a fieldbus interruption, all load outputs will be set to the status OFF.</p> <p>bit 2 = power saving mode, the LEDs will be dimmed for power reduction.</p> <p>bit 3 = reserve bit 4 = reserve bit 5 = reserve bit 6 = reserve bit 7 = reserve</p> <p>If not described otherwise, »True« means that the function is active.</p>
Control commands disable <b>ELBus</b> <sup>®</sup> 1 on CPC channel 1 ... 16	1 HighByte 2 LowByte	UInt16	0 ... 65535	<p>Each bit represents a channel. (bit 0 = channel 1; bit1 = channel 2 ...)</p> <p>If the bit is set, this means that the channel cannot be switched on or off via the control unit or the web server.</p>
Control commands disable <b>ELBus</b> <sup>®</sup> 1 on CPC channel 17 ... 32	3 HighByte 4 LowByte	UInt16	0 ... 65535	<p>Each bit represents a channel. (bit 0 = channel 17; bit1 = channel 18 ...)</p> <p>If the bit is set, this means that the channel cannot be switched on or off via the control unit or the web server.</p>
Reserve	5 HighByte 6 LowByte	UInt16	0	Reserve
Reserve	7 HighByte 8 LowByte	UInt16	0	Reserve

fig. 18: Configuration data CPC12

### 9.1.3 Action commands CPC12 controller

The action commands of the controller consist of 1 byte. All action commands being sent to the CPC12 carry out the action for all channels.

Class ID = 100, Instance ID = 1 and Attribute ID = 4

Service Code: Set\_Attribute\_Single (16)

Action commands with possible conditions are described in the following table.

	Byte	Type	Range	Description
Action commands	0	byte	0 ... 255	116 = reset trip counter 118 = reset device parameters to factory settings including CPC12 <sup>1)</sup> 131 = back to box <sup>2)</sup> 132 = adopt device type configurations to connected devices (see chapter 9.2.3). 192 = reset statistics minimum values 196 = reset statistics maximum values 220 = reset statistics mean values Other values will not be accepted.

fig. 19: Action commands CPC12

<sup>1)</sup> The command »118 = reset device parameters to factory settings including CPC12« within the action commands for the CPC12 shall reset the following data:

- parameters (current ratings = 10 A, limit value load current = 80 %) of each channel
- PLC lock bit of each channel (default = True, i.e. Channel not to be controlled by the PLC)
- **not** the configured device types
- **not** the statistical values (min, max, avg) of the channels
- **not** the error memory, trip counter and trip reason of the channels
- configuration data
  - power saving mode = False = LEDs normal
  - behavior of load outputs after fieldbus interruption = True = status is maintained
  - writing via web server permitted = True

<sup>2)</sup> The command »131 = back-to-box« within the action commands for the CPC12 shall reset the following data:

- Parameters (rated current = 10 A, limit value load current = 80 %) of each channel
- PLC lock bit of each channel (default = True, i.e. Channel not controllable by PLC)
- configured device types (default = REX12D-TA1 = 0x9009 = 36873)
- the statistical values (min, max, avg) of the channels
- the error memory, trip counter and trip reason of the channels
- configuration data
  - power saving mode = False = LEDs normal
  - behavior of the load outputs on fieldbus interruption = True = Status is maintained
  - Writing via web server permitted = True
- IP configuration of the third ETH port X1
  - IP address = 192.168.1.1
  - Netmask = 255.255.255.0
  - gateway = 192.168.1.254
  - DHCP = False
- User data
  - Name = »admin«
  - Password = »admin«

### 9.1.4 Dynamic information CPC12 controller

The dynamic information for the controller consists of 4 bytes.

Class ID = 100, Instance ID = 1 and Attribute ID = 2

Service Code: Get\_Attribute\_Single (14)

	Byte	Type	Range	Description
Cycle time <b>ELBus®</b> 1	0 HighByte 1 LowByte	UInt16	0 ... 65535	Holds the internal cycle time of the <b>ELBus®</b> in milliseconds [ms].
Reserve	2 HighByte 3 LowByte	UInt16	0 ... 65535	Reserve

fig. 20: Dynamic information CPC12

## 9.2 Circuit protectors/channels

The parameters of the circuit protectors are described in the following chapters. The parameters are organised in channels.

### 9.2.1 Device parameters for one channel

The device parameters for one channel consist of 2 bytes.

Class ID = 101, Instance ID = 1...32 and Attribute ID = 3

Service Code: Get\_Attribute\_Single (14), Set\_Attribute\_Single (16)

All device parameters with possible conditions are described in the following table.

	Byte	Type	Range	Description
Rated current	0	byte	1 ... max. rated current of the circuit breaker	Holds the current rating of the channel. With adjustable devices, you can set a new current rating here and transmit with a write command. 1 = 1A current rating 2 = 2A current rating 3 = 3A current rating ... 10 = 10A current rating (default value)
Limit value load current	6	byte	50 ... 100	Determines at which percentage of the current rating of a channel the limit value is exceeded. Exceedance is signaled with a bit in the »status channel« of the cyclical data. The range is from 50 % to 100 %. The default value is 80 %.

fig. 21: Device parameters channel

### 9.2.2 Device information for one channel

The device information for one channel consists of 19 bytes.

Class ID = 101, Instance ID = 1...32 and Attribute ID = 1

Service Code: Get\_Attribute\_Single (14)

All device information with possible conditions are described in the following table.

	Byte	Type	Range	Description
Circuit breaker p/n	0 HighByte 1 LowByte	UInt16	0 ... 65535	36873 = REX12D-TA1-100 36874 = REX12D-TA2-100 36873 = REX12D-TA1-100 36874 = REX12D-TA2-100 36878 = REX12D-TE2-100 36910 = REX12D-TE2-100-CL2 36905 = REX12D-TB1-100 36937 = REX12D-TA1-100-CL2 36969 = REX12D-TB1-100-CL2

⋮

	Byte	Type	Range	Description
Circuit breaker p/n	0 HighByte 1 LowByte	UInt16	0 ... 65535	36906 = REX12D-TA2-100-CL2 36942 = REX12D-TE2-101 36974 = REX12D-TE2-101-CL2 37001 = REX12D-TA1-101 36938 = REX12D-TA2-101 37033 = REX12D-TB1-101 37065 = REX12D-TA1-101-CL2 37097 = REX12D-TB1-101-CL2 36970 = REX12D-TA2-101-CL2 37130 = REX22D-TD2-100-CL2 37162 = REX22D-TD2-100 37129 = REX22D-TD1-100 37161 = REX22D-TA1-100 37134 = REX22D-TE2-100 37166 = REX22D-TE2-100-CL2 37194 = REX22D-TD2-101-CL2 37226 = REX22D-TD2-101 37193 = REX22D-TD1-101 37225 = REX22D-TA1-101 37198 = REX22D-TE2-101 37230 = REX22D-TE2-101-CL2 This list may be extended by future circuit protectors.
Hardware version	2 HighByte 3 LowByte	UInt16	0 ... 65535	Holds the hardware version of the installed product
Internal assembly order	4 HwHb 5 HwLB 6 LwHB 7 LwLB	UInt32	0 ... 4294967295	Holds the assembly order number of the installed product
Internal order split number	8 HighByte 9 LowByt	UInt16	0 ... 65535	Holds the internal order split number of the installed product
Production facilities number	10 HighByte 11 LowByte	UInt16	0 ... 65535	Holds the production facilities number of the installed product
Serial number	12 HwHb 13 HwLB 14 LwHB 15 LwLB	UInt32	0 ... 4294967295	Holds the serial number of the installed product
Software version (major.x.x)	16	byte	0 ... 255	Holds the major software version of the installed product
Software version (x.minor.x)	17	byte	0 ... 255	Holds the minor software version of the installed product
Software version (x.x.build)	18	byte	0 ... 255	Holds the build software version of the installed product

fig. 22: Device information channel

### 9.2.3 Configuration data for one channel

The configuration data for one channel consist of 2 bytes.

Class ID = 101, Instance ID = 1...32 and Attribute ID = 6

Service Code: Get\_Attribute\_Single (14), Set\_Attribute\_Single (16)

All configuration data with possible conditions are described in the following table.

	Byte	Type	Range	Description
Circuit breaker p/n	0 HighByte 1 LowByte	UInt16	0 ... 65535	<p>The expected device type is adjusted here for the channel. The device type always influences a circuit protector, i.e. both possible channels.</p> <p>36873 = REX12D-TA1-100 36874 = REX12D-TA2-100 36873 = REX12D-TA1-100 36874 = REX12D-TA2-100 36878 = REX12D-TE2-100 36910 = REX12D-TE2-100-CL2 36905 = REX12D-TB1-100 36937 = REX12D-TA1-100-CL2 36969 = REX12D-TB1-100-CL2 36906 = REX12D-TA2-100-CL2 36942 = REX12D-TE2-101 36974 = REX12D-TE2-101-CL2 37001 = REX12D-TA1-101 36938 = REX12D-TA2-101 37033 = REX12D-TB1-101 37065 = REX12D-TA1-101-CL2 37097 = REX12D-TB1-101-CL2 36970 = REX12D-TA2-101-CL2 37130 = REX22D-TD2-100-CL2 37162 = REX22D-TD2-100 37129 = REX22D-TD1-100 37161 = REX22D-TA1-100 37134 = REX22D-TE2-100 37166 = REX22D-TE2-100-CL2 37194 = REX22D-TD2-101-CL2 37226 = REX22D-TD2-101 37193 = REX22D-TD1-101 37225 = REX22D-TA1-101 37198 = REX22D-TE2-101 37230 = REX22D-TE2-101-CL2</p> <p>This list may be extended by future circuit protectors.</p>

fig. 23: Configuration data channel

## 9.2.4 Event message for one channel

The event messages for one channel consist of 1 byte.

Class ID = 101, Instance ID = 1...32 and Attribute ID = 5

Service Code: Get\_Attribute\_Single (14)

All event messages with possible conditions are described in the following table.

	Byte	Type	Range	Description
Event	0	byte	0 ... 255	bit 0 = waiting for parameterisation bit 1 = reserve bit 2 = new current rating available bit 3 = channel off via momentary switch/switch bit 4 = reserve bit 5 = reserve bit 6 = reserve bit 7 = device error detected »True« means the status is active.

fig. 24: Event messages channel

## 9.2.5 Action commands for one channel

The action commands for one channel consist of 1 byte.

Class ID = 101, Instance ID = 1...32 and Attribute ID = 4

Service Code: Set\_Attribute\_Single (16)

All action commands with possible conditions are described in the following table.

	Byte	Type	Range	Description
Action commands	0	byte	0 ... 255	116 = reset trip counter 118 = reset device parameters to factory settings 1) 131 = back to box <sup>2)</sup> 192 = reset statistics minimum values 196 = reset statistics maximum values 220 = reset statistics mean values Other values will not be accepted.

fig. 25: Action commands channel

<sup>1)</sup> The command »118 = reset device parameters to factory settings« within the action commands per channel shall reset the following data:

- parameters (current ratings = 10 A, limit value load current = 80 %) of each channel
- PLC lock bit of each channel (default = True, i.e. channel not to be controlled by the PLC)
- **not** the configured device types
- **not** the statistical values (min, max, avg) of the channels
- **not** the error memory, trip counter and trip reason of the channels

<sup>2)</sup> The command »131 = back-to-box« within the action commands per channel shall reset the following data:

- Parameters (rated current = 10 A, limit value load current = 80 %) of each channel
- PLC lock bit of each channel (default = True, i.e. channel not controllable by PLC)
- configured device types (default = REX12D-TA1 = 0x9009 = 36873)
- the statistical values (min = 655.35 A/V, max = 0 A/V, avg- 0 A/V) of the channel
- the error memory, trip counter and trip reason of the channel



## 9.2.6 Diagnostic data for one channel

The dynamic information for one channel consists of 22 bytes.

Class ID = 101, Instance ID = 1...32 and Attribute ID = 2

Service Code: Get\_Attribute\_Single (14)

All dynamic information with possible conditions is described in the following table.

	Byte	Type	Range	Description
Error memory	0 HighByte 1 LowByte	UInt16	0 ... 65535	bit 0 = no parameters available bit 1 = error parameter memory bit 2 = error programme memory bit 3 = error data memory bit 4 = error control unit bit 5 = reset through watchdog bit 6 = reserve bit 7 = reserve bit 8 = reserve bit 9 = reserve bit 10 = reserve bit 11 = reserve bit 12 = reserve bit 13 = reserve bit 14 = reserve bit 15 = reserve »True« means the status is active.
Trip counter	2 HighByte 3 LowByte	UInt16	0 ... 65535	The number of trippings since the last reset of is shown here.
Reason for trip	4	byte	0 ... 255	0 = no trip 1 = short circuit 2 = overload 3 = device temperature too high 4 = internal device failure
Min. Load voltage	5 HighByte 6 LowByte	UInt16	0 ... 65535	Contains the highest measured voltage of the channel since the last reset. A standardised 16-bit-value with a resolution of 10 mV is made available. Example for calculation of the measuring value: value (2512)/100 $\hat{=}$ 25.12 Volt
Max. Load voltage	7 HighByte 8 LowByte	UInt16	0 ... 65535	Contains the highest measured voltage of the channel since the last reset. A standardised 16-bit-value with a resolution of 10 mV is made available. Example for calculation of the measuring value: value (2512)/100 $\hat{=}$ 25.12 Volt
Medium value Load voltage	9 HighByte 10 LowByte	UInt16	0 ... 65535	Contains the mean voltage value of the channel since the last reset. A standardised 16-bit-value with a resolution of 10 mV is made available. Example for calculation of the measuring value: value (2512)/100 $\hat{=}$ 25.12 Volt
Min. load current	11 HighByte 12 LowByte	UInt16	0 ... 65535	Contains the lowest measured current of the channel since the last reset. A standardised 16-bit-value with a resolution of 10 mA is made available. Example for calculation of the measuring value: value (150)/100 $\hat{=}$ 1.50 Amps

⋮

	Byte	Type	Range	Description
Max. load current:	13 HighByte 14 LowByte	UInt16	0 ... 65535	Contains the highest measured current of the channel since the last reset. A standardised 16-bit-value with a resolution of 10 mA is made available. Example for calculation of the measuring value: value (150)/100 $\hat{=}$ 1.50 Amps
Medium value load current	15 HighByte 16 LowByte	UInt16	0 ... 65535	Contains the mean current value of the channel since the last reset. A standardised 16-bit-value with a resolution of 10 mA is made available. Example for calculation of the measuring value: value (150)/100 $\hat{=}$ 1.50 Amps
Supply voltage / actuator voltage	17 HighByte 18 LowByte	UInt16	0 ... 65535	Holds the supply voltage / actuator voltage of the channel. A standardised 16-bit-value with a resolution of 10 mV is made available. Example for calculation of the measuring value: value (2512)/100 $\hat{=}$ 25.12 Volt
Reserve	19 HighByte 20 LowByte	UInt16	0 ... 65535	Reserve
Diagnostic information of the channel	21	byte	0 ... 255	0 = OK 1 = available device type does not match the configured type 2 = no device detected 3 = unused channel 144 = device parameters not plausible 146 = channel off via momentary switch/switch 147 = detected undervoltage 148 = detected excess temperature 149 = reset command required 150 = command was processed correctly 151 = parameterisation required 152 = Internal failure detected 153 = unknown command 154 = set length error 155 = rated current available, check sum error 156 = current rating selector switch was actuated

fig. 26: Dynamic information

# 10 Appendix

## 10.1 List of pictures

fig. 1: System overview	6
fig. 2: Dimensions CPC12	7
fig. 3: Status indication and terminals	7
fig. 4: Display status LEDs	8
fig. 5: Display fieldbus status LEDs	9
fig. 6: Display LEDs RJ45 connectors	9
fig. 6: Installation drawing	9
fig. 8: Communication properties	12
fig. 9: Identity Object Attributes	13
fig. 10: TCP/IP Interface Object Attributes	13
fig. 11: Cyclical diagnostic data CPC12	14
fig. 12: Total current	14
fig. 13: Input data circuit protector	15
fig. 14: Output data circuit protector	16
fig. 15: CPC12 Object Attributes	17
fig. 16: Channel Object Attributes	17
fig. 17: Device information CPC12	18
fig. 18: Configuration data CPC12	19
fig. 19: Action commands CPC12	20
fig. 20: Dynamic information CPC12	21
fig. 21: Device parameters channel	21
fig. 22: Device information channel	22
fig. 23: Configuration data channel	23
fig. 24: Event messages channel	24
fig. 25: Action commands channel	24
fig. 26: Dynamic information	26

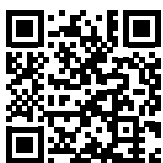

[www.e-t-a.de/qr1045/](http://www.e-t-a.de/qr1045/)

Bedienungsanleitung/Instruction manual CPC12EN-Tx-xxx (ENG)  
Bestell-Nr. / Ref. number Y31363902 - Index: -  
Issue 01/2021  
Alle Rechte vorbehalten / All rights reserved



E-T-A Elektrotechnische Apparate GmbH  
Industriestraße 2-8 · 90518 Altdorf  
GERMANY  
Phone +49 9187 10-0 · Fax +49 9187 10-397  
E-mail: [info@e-t-a.de](mailto:info@e-t-a.de) · [www.e-t-a.de](http://www.e-t-a.de)